

1 2 3 4

CUSTOMER SIGNATURE

修改日期 DATE	版次 VERSION	變更內容 REVISION

A

B

C

D

E

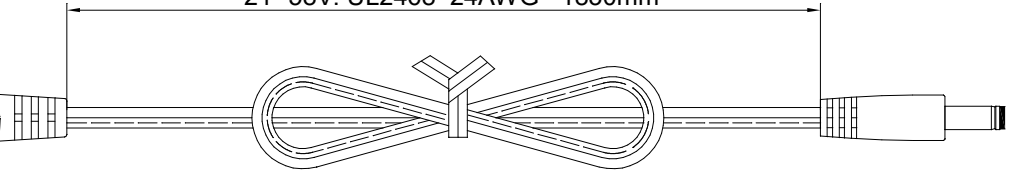
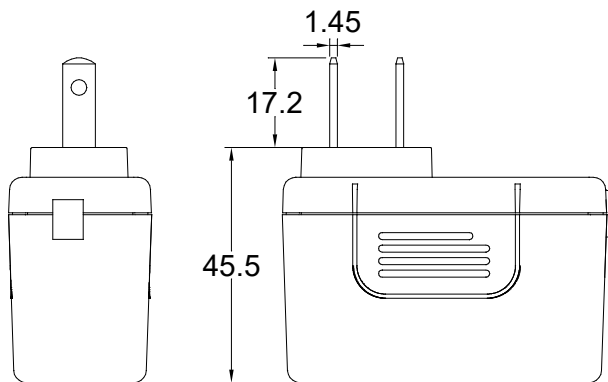
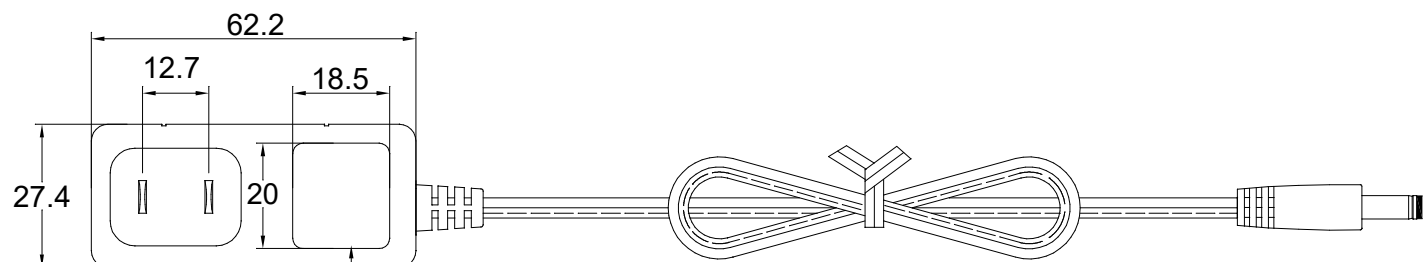
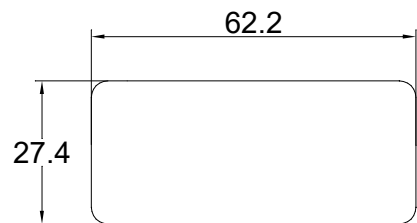

育鉦科技股份有限公司 ELJINTEK, INC.	繪圖 DWG.BY.	校對 CHK.BY.	安規人員確認 Agency approvals CHK.	承認 APP.BY.	TOLERANCE	材質 MATERIAL	圖稱 DWG.TITLE	日期 DATE	MODEL			APSU25U	
							Outline drawing	比例 SCALE	NONE	單位 UNIT	m/m	正式圖面 Final DWG.	圖號 DWG.NO.
						處理 FINISH		修訂 REVISION	0	角位 ANGLE		非正式圖面 Temporary DWG.	編號 SERIAL